

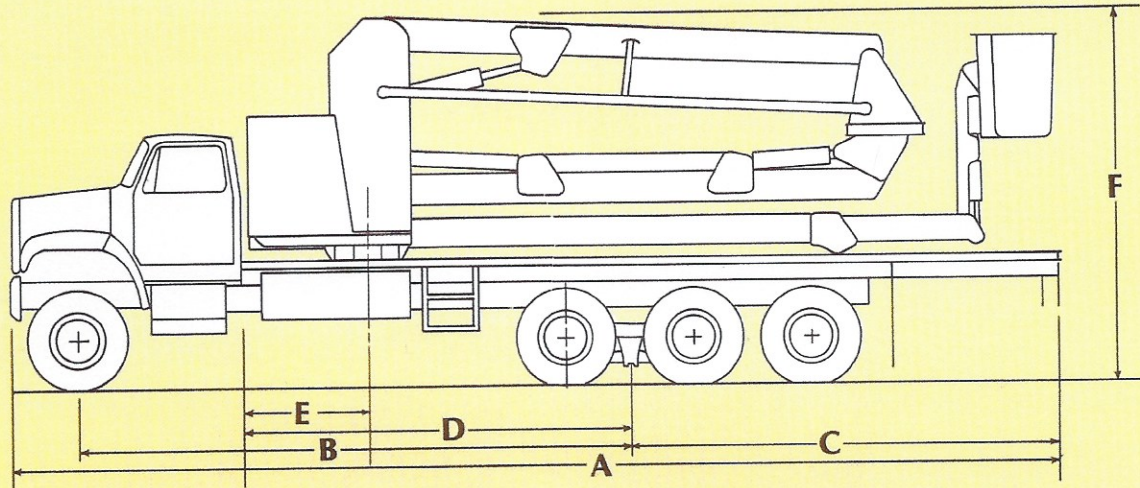

BRIDGE INSPECTION UNITS MODELS UB40/UB50/UB60



WORKING RANGE DIAGRAM

MODELS
UB40/UB50
UB60

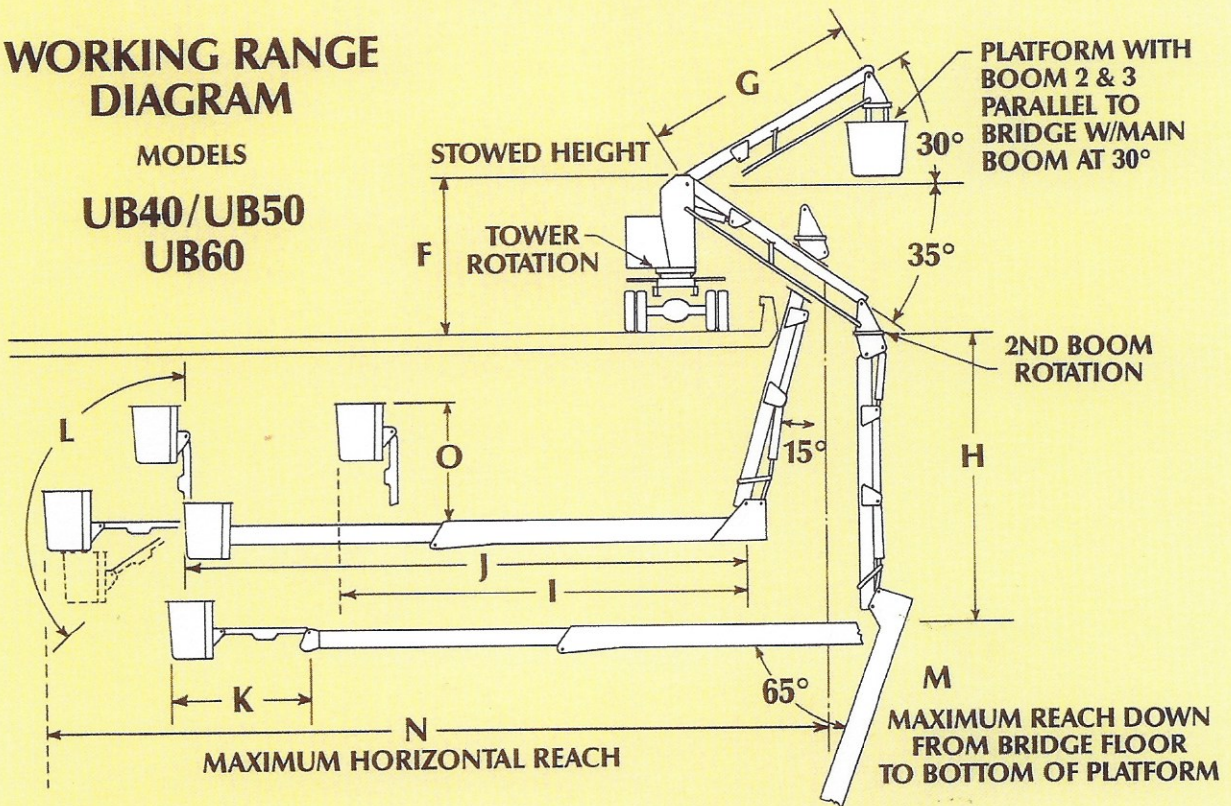

DIMENSION	A	B	C	D	E	F	G	H	I	J	K	L	M	N	O
MODEL UB40	34'0" (10.4 m)	18'7" (5.7 m)	11'8" (3.6 m)	13'0" (4.0 m)	4'3" (1.3 m)	12'10" (3.9 m)	15'5" (4.7 m)	20'1" (6.1 m)	18'6" (5.6 m)	38'3" (11.7 m)	N/A	N/A	52'0" (15.8 m)	42'10" (13.1 m)	N/A
MODEL UB50	37'0" (11.3 m)	19'2" (5.8 m)	14'11" (4.6 m)	14'4" (4.4 m)	4'3" (1.3 m)	13'3" (4.0 m)	16'11" (5.2 m)	24'1" (7.3 m)	24'8" (7.5 m)	37'8" (11.5 m)	8'0" (2.4 m)	125°	63'0" (19.2 m)	51'9" (15.8 m)	7'1" (2.2 m)
MODEL UB60	41'0" (12.5 m)	19'2" (5.8 m)	17'3" (5.3 m)	14'4" (4.4 m)	4'3" (1.3 m)	13'0" (4.0 m)	16'11" (5.2 m)	24'1" (7.3 m)	32'10" (10.0 m)	44'2" (13.5 m)	9'3" (2.8 m)	136°	70'0" (21.3 m)	60'6" (18.4 m)	9'9" (3.0 m)

The specifications and description listed herein were approved at the time of initial printing and are subject to change without incurring any liability. Also, this specification describes the operating parameters of a total bridge inspection unit system and is not intended to imply what is or is not included in the base price of the ASPEN AERIALS, INC. price list for this information.